

**CLIP-ON STRAIGHT JACK CRIMP TYPE**

**R120.237.510**

**CABLE 2.6/50 S**

Series : **DIN 41626**

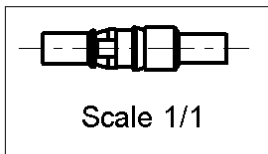
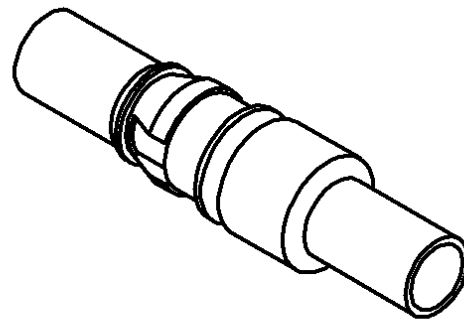
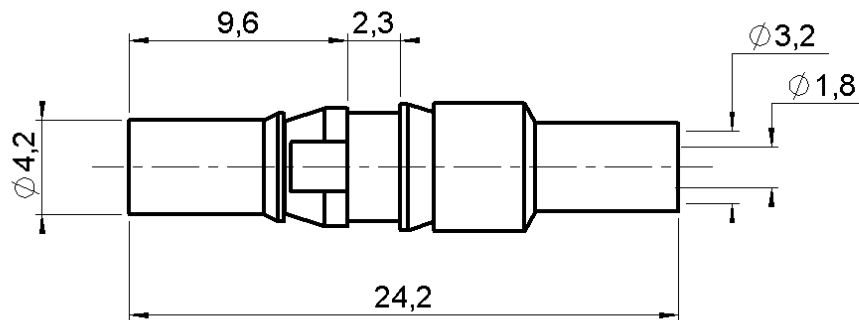

All dimensions are in mm.



COMPONENTS	MATERIALS	PLATINGS (µm)
BODY	BRASS	GOLD .
CENTER CONTACT	BERYLLIUM COPPER	GOLD .
OUTER CONTACT	-	-
INSULATOR	PTFE	-
GASKET	-	-
OTHERS PARTS	-	-
-	-	-
-	-	-

Issue : 9912 B

In the effort to improve our products, we reserve the right to make changes judged to be necessary.



**CLIP-ON STRAIGHT JACK CRIMP TYPE**

**R120.237.510**

**CABLE 2.6/50 S**

Series : **DIN 41626**

**PACKAGING**

Standard	Unit	Other
<b>100</b>	<b>'W' option</b>	<b>Contact us</b>

**SPECIFICATION**

**ELECTRICAL CHARACTERISTICS**

Impedance		<b>50</b> Ω
Frequency		<b>0-2</b> GHz
VSWR	<b>1.35 +</b>	<b>0.000</b> x F(GHz) Maxi
Insertion loss		<b>NA</b> √F(GHz) dB Maxi
RF leakage	- (	<b>NA</b> - F(GHz)) dB mini
Voltage rating		<b>250</b> Veff Maxi
Dielectric withstanding voltage		<b>750</b> Veff mini
Insulation resistance		<b>5000</b> MΩ mini

**CABLE ASSEMBLY**

Stripping	a	b	c	d	e	f
mm	2.00	5.00	9.00	0.00	7.00	0.00

Assembly instruction :

Recommended cable(s)  
 KX 22A  
 RG 316  
 RG 188

Cable retention

- pull off **40** N mini  
 - torque **NA** N.cm

**MECHANICAL CHARACTERISTICS**

Center contact retention		
Axial force – Mating end	<b>10</b>	N mini
Axial force – Opposite end	<b>10</b>	N mini
Torque	<b>NA</b>	N.cm mini

**TOOLING**

Part Number	Description	Hexagon
.	.	.
R282.211.000	CRIMPING TOOL	3.25
R282.235.003	CRIMPING DIES	3.25
R282.293.000	CRIMPING TOOL	-

Recommended torque		
Mating	<b>NA</b>	N.cm
Panel nut	<b>NA</b>	N.cm
Clamp nut	<b>NA</b>	N.cm
A/F clamp nut	<b>0.000</b>	mm

**OTHERS CHARACTERISTICS**

Mating life	<b>500</b>	Cycles mini
Weight	<b>1.800</b>	g

**ENVIRONMENTAL**

Operating temperature	<b>-55/+155</b>	° C
Hermetic seal	<b>NA</b>	Atm.cm3/s
Panel leakage	<b>NA</b>	

Issue : **9912 B**

In the effort to improve our products, we reserve the right to make changes judged to be necessary.



**CLIP-ON STRAIGHT JACK CRIMP TYPE**

**R120.237.510**

**CABLE 2.6/50 S**

Series : DIN 41626

**COMPONENTS**

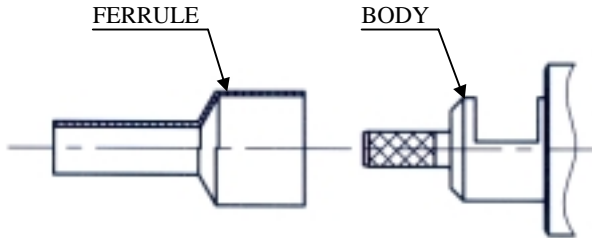

**STRIPPING DIMENSIONS**

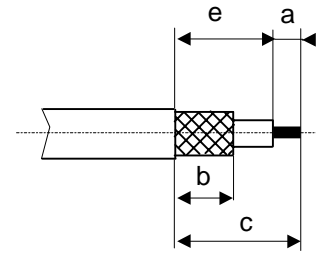

**1**



Slide the ferrule onto the cable.  
Strip the cable.

**3**

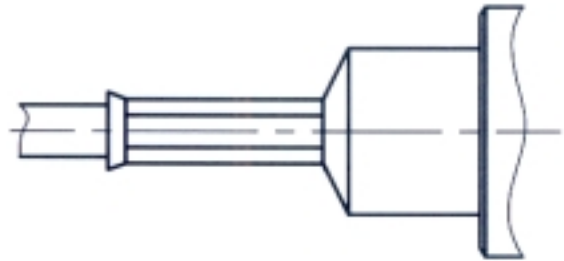

Crimp the ferrule with crimping tool (see connector TDS ).  
Cut the excess of braid if necessary.

**2**

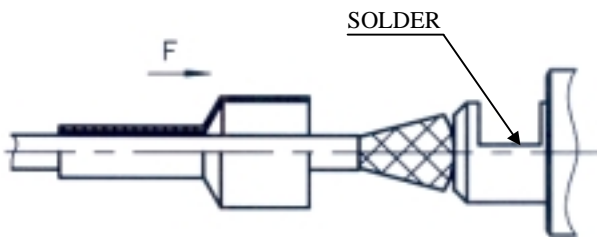

Fan the braid.  
Push the connector body under the braid.  
Slide the center contact on until it bottoms against the cable dielectric.  
Solder the center contact.  
Push the connector body under the braid.  
Slide the ferrule over the braid in direction F.

**Issue : 9912 B**

In the effort to improve our products, we reserve the right to make changes judged to be necessary.

